

TIMBA STOOL

ALL WORK AND SOME PLAY

The new swivelling stool from Bene gets things moving in the office! The TIMBA Stool blends in easily and seamlessly with the informal collaboration and team zones of contemporary office concepts. With its informal character, the TIMBA Stool is a clear counterpoint to the strictness of classical seating furniture, and helps to create an atmosphere in which the process of communication and creativity

can unfold. As an ideal opportunity for teamwork and informal exchange, the TIMBA Stool is open to the various forms of office activities. The round seat of the stool has a surprise in store for you: it can be swivelled and allows you to move optimally during a conversation. The unsuspected swivel function of the seating shell allows you a lot of flexibility and mobility during brief discussions.

Design: PearsonLloyd



bene

INSPIRING OFFICES. SINCE 1790.

PRODUCT DESCRIPTION

- 1 **Seat:** Seat shell made of fibreglass-reinforced plastic in off-white or dark grey, with upholstery in fabric group PO-P4 or with a leather cover in L1 black.
- 2 **Backrest:** Optional. Colour always same as the seat shell.
- 3 **Legs:** Solid oak. The standard version comes with plastic glides, optionally with felt glides.
- 4 **Foot ring:** Made of fibreglass-reinforced plastic in dark grey.

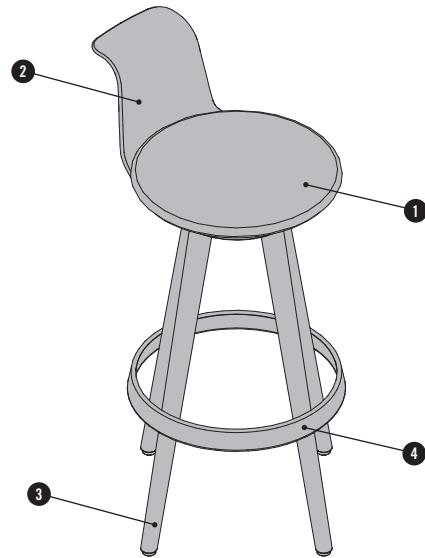

OVERVIEW & DIMENSIONS

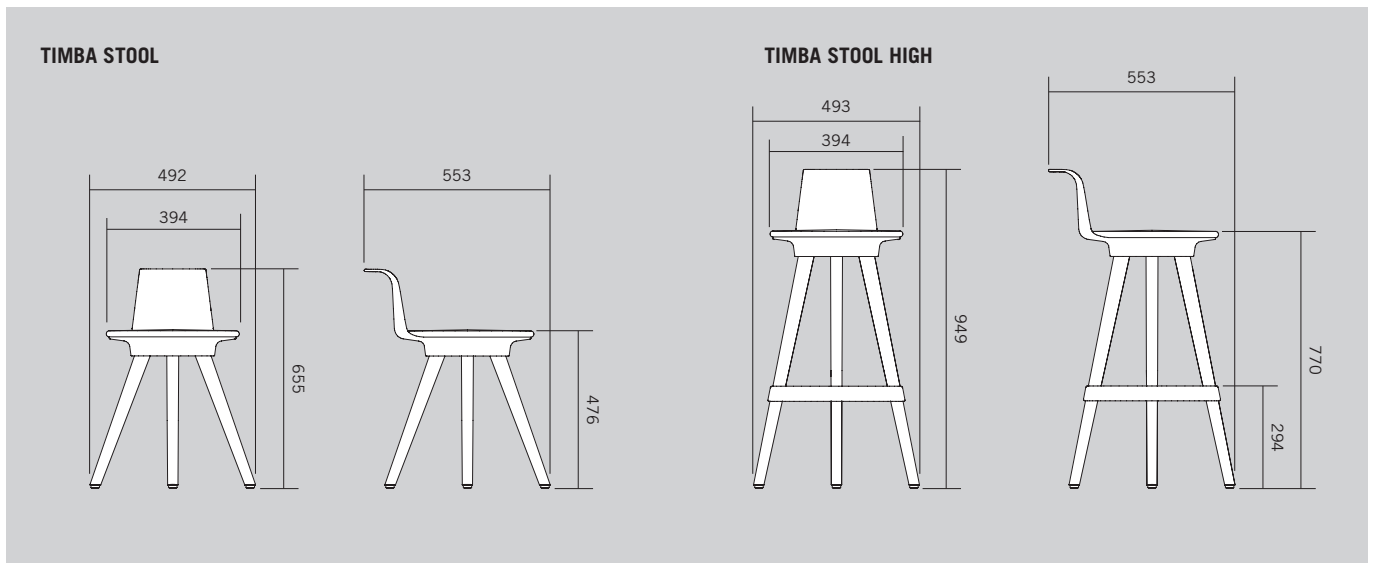

COLOURS & MATERIALS

SOLID WOOD: Oak

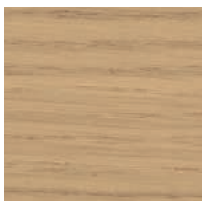

HC natural oak

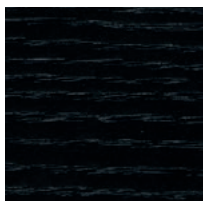

HD oak graphite

PLASTIC SURFACE

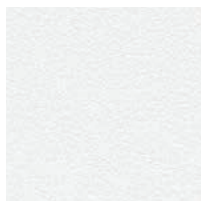

off-white

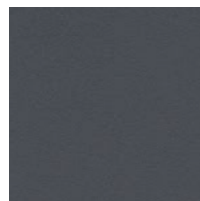

dark grey

BENE WORKS SUSTAINABLY

Bene plays a leading role in responsible environmental management. It is practised throughout all company divisions—from product development, procurement, production and logistics to product recycling. Bene considers ecology to be a central element of its responsible and sustainable corporate strategy. Bene sees the legal regulations as minimum requirements and strives for better and more sustainable environmental protection throughout the group. The Bene principle in environmental policy is: **Avoidance—Minimisation—Recycling—Disposal.**

TIMBA STOOL— ECOLOGICAL STANDARDS

- 84.2% recyclable
- 48.9% of contents are renewable raw materials
- Resource-conserving product design
- Use of certified wood (chain of custody)
- Use of materials tested for presence of hazardous substances
- No PVC, chromium, lead or mercury
- Individual parts can be sorted according to homogeneous categories
- Recyclable and with positive contribution to the carbon footprint (average 8.06 kg CO₂)

TIMBA STOOL LEED POINTS

The Leadership in Energy and Environmental Design (LEED) is a system to classify ecological construction. It was developed by the U.S. Green Building Council. As an internationally recognised standard, it defines numerous standards for environmentally friendly, resource conserving and sustainable construction. The use of the TIMBA Stool is an important contribution to LEED certification. The following criteria for this are from »LEED 2009 for Commercial Interiors«:

MR Credit 5	Regional materials	up to 2 points
MR Credit 7	Certified wood	up to 1 point
IEQ Credit 4.5	Material with low hazardous substance content	up to 1 point

TIMBA STOOL MATERIAL COMPONENTS*

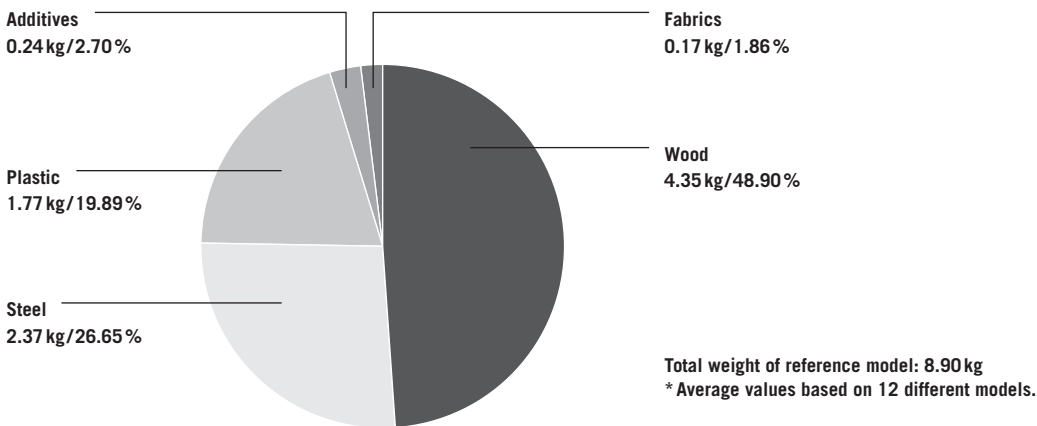

Environment-related information about Bene: www.bene.com/sustainability

